

## Optional Extension Activity

### HOOKS AND LADDERS

(Adapted from Aquatic Project Wild)

#### Subject

Science

#### Objectives

Students will be able to: (1) recognize that some fish migrate as part of the life cycle; (2) identify the stages of the life cycle of one kind of fish; (3) describe limiting factors affecting Pacific salmon as they complete their life cycle; and (4) generalize that limiting factors affect all populations of animals.

#### Materials

~~that can be~~

- A jump rope (10 - 15 feet long)
- About 500 feet of surveyors flagging (or something to designate playing area boundaries)
- Traffic cones (optional)
- 2 cardboard boxes
- 100 tokens (poker chips)

Large playing area (100 feet x 50 feet)

#### Size/Setting/Duration

Whole Class/Playing Field/~1 hour

#### Background

Many fish live part of their lives in one habitat and then migrate to another habitat. Some make their migratory journeys to mature and reproduce. Pacific salmon are an example of one of the most spectacular of the migrating species.

Pacific salmon are destined to spawn only once in their lifetime. Within their genetic fiber is an encoded instinct that drives them from the time of hatching along a monumental journey from their freshwater spawning beds downstream into the sea. Once in the sea, they spend several years reaching the maturity needed for their single return journey to their original hatching ground. Once there, the salmon spawn and die.

Salmon must face a myriad of hazards that serve as limiting factors in the completion of their life cycle. Limiting factors are factors that reduce the populations of living organisms. Sometimes the

limiting factor is natural and sometimes they result from human intervention with natural systems.

The female Pacific salmon deposits 1,500 to 7,000 eggs in her freshwater spawn. The eggs are deposited in a shallow gravel depression scooped out by the female called a redd. Once deposited, the male fertilizes the eggs and then both fish nudge the gravel back over the eggs to offer as much protection as possible. Within a few days both the female and male salmon have completed their reproduction and soon die.

The eggs, before and after hatching, are susceptible to many limiting factors. Smothering silt can be washed in suddenly from watersheds damaged by a variety of land-use practices and events - including erosion following some road building, logging, and fires. Predators can eat some of the eggs and damage hatching populations. Dropping water levels can isolate salmon offspring in streamside depressions and cause them to remain isolated and die. After hatching, the small fish - called "alevins" - spend their first two weeks hiding in the gravel. Gradually they absorb their yolk sac and become known as "fry." If they survive the first two weeks, then they begin their journeys. Some swim directly to sea.

Depending on the species, young salmon may spend several months to as much as a year or more in the river before migrating to the estuary and then to the open ocean.

The small ocean-bound salmon, now called "smolts," are at once confronted by hazards on their downstream journey. Examples are dams; low water in streams; and predatory birds, mammals, and larger fish. Up to 90% of the salmon that hatch never reach the sea.

When in the ocean, the salmon grow rapidly by feeding on the ocean's rich food supply. Predators such as sharks, killer whales, and other marine mammals take their toll. In addition, humans fish for salmon commercially and for personal reasons, including food and recreation.

In two to five years, the Pacific salmon start the journey that will guide them back to the rivers and streams leading to their own hatching site. The upstream migration from the ocean is also a series of hazards. For example, dams hinder their journey and would block it completely if fish ladders were not installed. Fish ladders are water filled staircases that allow the migrating fish to swim upstream, around the dam. Humans who fish, bears, and other predatory

mammals also reduce the numbers along the way to the spawning ground. Sometimes landslides and logjams provide unexpected new barriers. So too do the natural waterfalls and rapids that the now weighty salmon must overcome. Once back at the spawning ground the life cycle of the Pacific salmon begins anew. To maintain the Pacific salmon population, some biologists believe that only one pair of fish must return to deposit and fertilize the eggs.

All possible conditions are not covered by the design of this activity. However, the activity does serve simply and effectively to illustrate three important concepts - life cycle, migration, and limiting factors.

The major purpose of this activity is for students to gain an understanding of some of the complex characteristics of the life cycle of one representative aquatic species, the Pacific salmon.

### Activity

1. Begin by asking the students what they know about the life cycle of fish that live in their area. Do any local fish migrate to spawn? If yes, which ones? (Mullet, shad, lake trout, striped bass, suckers, carp, and salmon are examples of fish that migrate to spawn.) In this activity, students will learn about some of the characteristics of one species of fish that migrates as a part of its life cycle - the Pacific salmon.

2. This is a physically involving activity! Set up a playing field as shown in the attached diagram, including spawning grounds, downstream, upstream, and ocean (if space is limited, the same stretch of playing area can be both the downstream and upstream channels). The area must be about 100 feet by 50 feet. Assign roles to each of the students. Some will be salmon; others will be potential hazards to the salmon. Assign the students roles as follows.

- Choose two students to be the turbine team. These are the ones who operate the jump rope, which represents the turbines in hydroelectric dams. Later in the simulation, when all the salmon have passed the turbine going downstream, these students move to the upstream side to become the waterfall-broad jump monitors.
- Choose two students to be predatory wildlife. At the start of the simulation the predators will be below the turbines where they catch salmon

headed down stream. Later in the activity when all the salmon are in the sea, these same two predators will patrol the area above the "broad jump" waterfalls. There they will feed on salmon just before they enter the spawning ground.

- Choose two students to be human fishing boats catching salmon in the open ocean. These students in the fishing boats must keep one foot in a cardboard box to reduce their speed and maneuverability.
- All remaining students are salmon.

NOTE: these figures are based on a class size of 25 - 30. If the group is larger or smaller, adjust the number of people who are fishing and predatory wild animals accordingly.

3. Begin the activity with all the salmon in the spawning ground. The salmon then start their journey downstream. The first major hazard is the turbines at the dam. At most dams there are escape weirs to guide migrating salmon past the turbines. The student salmon cannot go around the jump rope swingers, but they can slip under the swingers' arms if they do not get touched while doing so. A salmon dies if the turbine (jump rope) hits it. The turbine operators may change the speed at which they swing the jump rope.
- NOTE: Any salmon that "dies" at any time in this activity must immediately become part of the human-made ladders now used by migrating salmon to get past the barriers such as dams. The students who are the fish ladder kneel on the ground on their hands and knees with a body-wide space between them.
4. Once past the turbines, the salmon must get past some predatory wildlife. The predators below the turbine must catch the salmon with both hands - tagging isn't enough. Dead salmon are escorted by the predator to become part of the fish ladder.
- NOTE: Later the salmon that survive life in the open ocean will use the structure of the fish ladder -- by passing through it - to return to the spawning ground. NOTE: Both the predatory wildlife in the last downstream area and the people fishing in the open ocean must take dead salmon to the fish ladder site. This gets the predators the fishing boats off the field regularly, helping to provide a more realistic survival ratio.

5. Once in the open ocean, fishing boats can catch the salmon. The salmon must move back and forth across the ocean area in order to gather four tokens. Once each fish has four tokens (four years' growth), that fish can begin migration upstream. The year tokens can only be picked up one token at a time on each crossing. Remember that the salmon must cross the entire open ocean area to get a token. The "four years" these trips take make the salmon more vulnerable to and thus the fishing boats more readily catch them. For purposes of this simulation, the impact of this limiting factor creates a more realistic survival ration in the population before the salmon begin the return migration upstream.
6. Once four of the year tokens are gathered, the salmon can begin to upstream. The salmon must walk through the entire pattern of the fish ladder. This enforced trip through the fish ladder gives the students a hint of how restricting and tedious the upstream journey can be. *In the fish ladder, predators may not harm the salmon.*
7. Once through the ladder, the salmon faces the broad jump waterfall. The waterfall represents one of the natural barriers the salmon must face going upstream. Be sure the jumping distance is challenging but realistic. The two former turbine students will monitor the jump. The salmon must jump the entire breadth of the waterfall to be able to continue. If the salmon fails to make the jump, then it must return to the bottom of the fish ladder and come through again.
8. Above the falls, the two predators who started the simulation as the predators below the turbines are now the last set of limiting factors faced by the salmon. They represent bears - one example of predatory wildlife. Again, remember that the predators must catch the salmon with both hands. If they do catch a salmon, they must then take the student they caught to become part of the fish ladder.
9. The activity ends when all the salmon are gone before the spawning ground is reached - or when all surviving salmon reach the spawning ground.
10. Next engage the students in a discussion. Explore such topics as:
  - The apparent survival-mortality ration of salmon
  - The students' feelings throughout the activity
  - The role of the barriers
  - The role of the predatory wildlife and the people fishing
  - Where the losses were the greatest
  - Where the losses were least
  - What the consequences would be if all the eggs deposited made the journey successfully
  - What seemed realistic about this simulation and what did not
11. Ask the students to summarize what they have learned about the life cycle of salmon, the salmon's migration, and limiting factors that affect salmon. Make sure the students have a clear working definition of limiting factors. Encourage the students to make the generalization that all animals - not just the Pacific salmon - are affected by limiting factors. Ask the students to give examples. They might mention availability of suitable food, water, shelter, and space; disease; weather; predation; and changes in land use as well as other human activities.

### SUGGESTIONS FROM EXPERIENCE

- Allow at least fifteen minutes for set-up.
- Have aides or parents participate in "crowd control" and monitoring. this if needed.
- Start with all the students in a classroom or some other contained space with limited distractions. Using the chalkboard, draw a simple diagram of the playing field and describe the general activity to them.
- Try to play two rounds of the activity. During the first, limit the barriers and limiting factors to those found in nature only (predators, waterfalls, etc). In the second round, add in human limiting factors (turbines, fishing boats, fish ladders, etc).
- At least during the first round of play, have all the salmon stop and wait after passing each hazard stretch. This way the salmon get a chance to regroup and contemplate the next barrier.
- Add an estuary area as a "holding area" for the salmon that have made it downstream to the ocean entrance and for those ready to head upstream to spawn.

# Set-Up for Hooks and Ladders

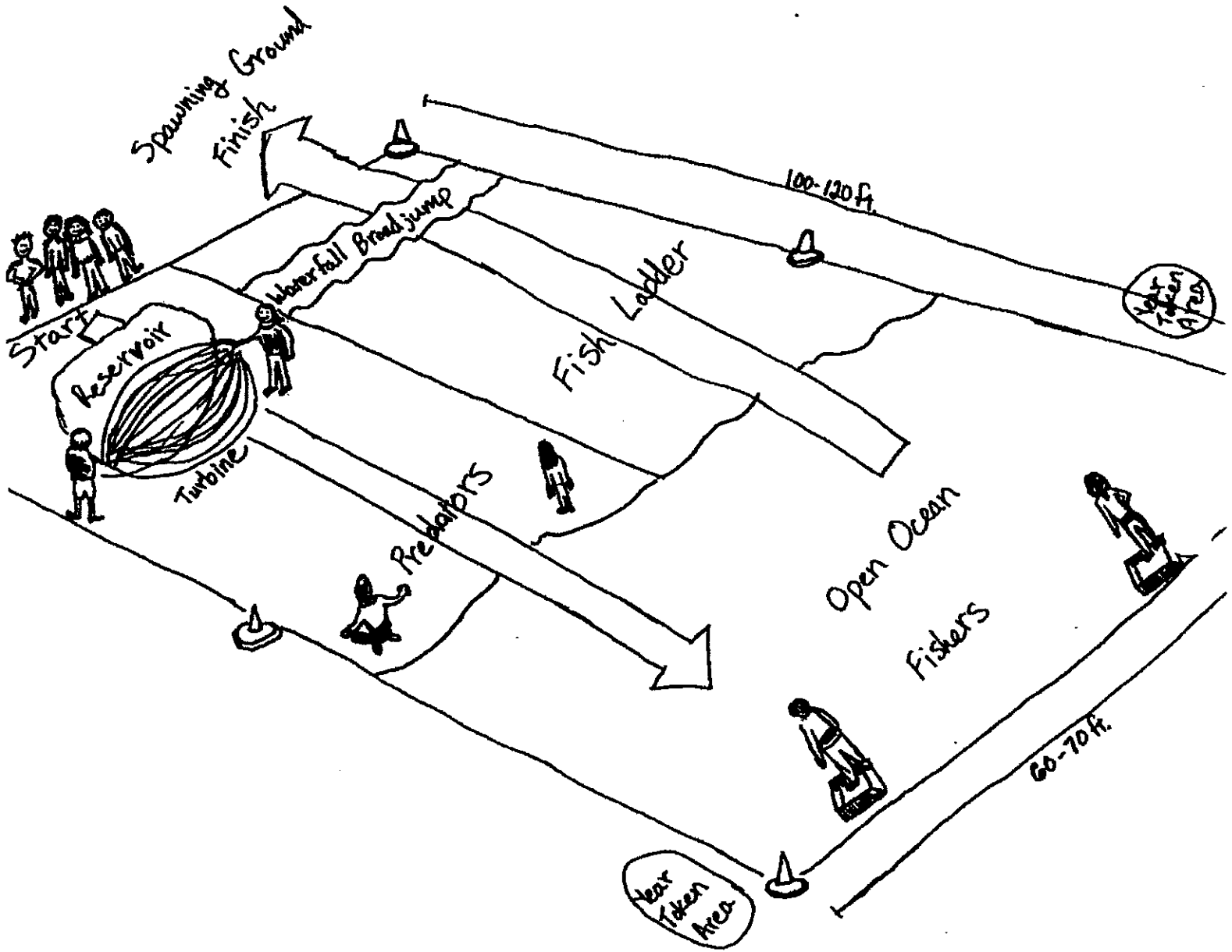

**EALR Information****Hooks and Ladders**

<b>Component</b>	<b>Benchmark</b>	<b>Assessment</b>
<b>1.2 Science</b> Recognize the components, structure, and organization of systems and the interconnections within and among them	Describe the life cycles of plants and animals.	Go through the different stages of Hooks and Ladders, each representing the different stages of a salmon's life
<b>1.3 Science</b> Understand how interactions within and among systems cause changes in matter and energy	Describe how an organism's ability to survive is influenced by its environment, other life forms, and availability of food and/or other resources. Describe how humans and other living things depend on the natural environment, and can cause changes in the environment that affect their ability to survive.	Ability to play Hooks and Ladders
<b>2.1 Science</b> Develop abilities necessary for scientific inquiry	Model objects, events, or processes by representing them with concrete objects, metaphors, analogies, or other conceptual or physical constructs.	Participation in the game of Hooks and Ladders